

# Hood

## User manual

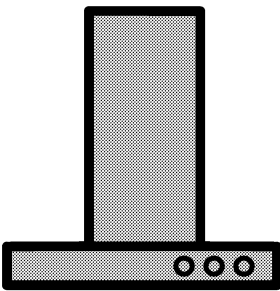

P 27 RAV  
P 27 RANT

**EN**

185.7300.10/03.10.2016

## Please read this user manual first!

Dear Customer,

Thank you for purchasing this Arçelik product. We hope that you get the best results from your product which has been manufactured with high quality and state-of-the-art technology. Therefore, please read this entire user manual and all other accompanying documents carefully before using the product and keep it as a reference for future use. If you handover the product to someone else, give the user manual as well. Follow all warnings and information in the user manual.

Remember that this user manual is also applicable for several other models. Differences between models will be identified in the manual.

### Explanation of symbols

Throughout this user manual the following symbols are used:

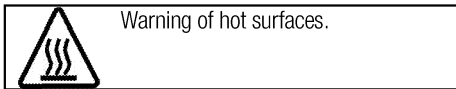
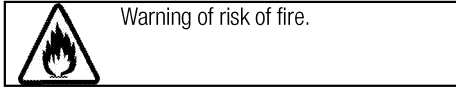
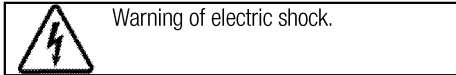
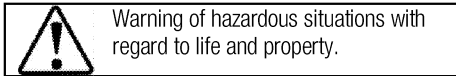
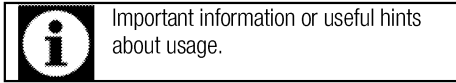

## TABLE OF CONTENTS

### **1 Important instructions and warnings for safety and environment 4**

General safety .....	4
Electrical safety .....	4
Product safety .....	5
Intended use .....	6
Children's safety .....	7
Compliance with AEEE regulation and disposal of waste products .....	7
Package information .....	7

### **2 General information 8**

Overview .....	8
Scope of delivery .....	9
Technical specifications .....	9

### **3 Installation 10**

Installation .....	10
Future transportation .....	13

### **4 Operating the hood 14**

### **5 Maintenance and care 15**

General information .....	15
Replacing the lamp .....	16

### **6 Troubleshooting 17**

### **7 Tüketici Hizmetleri 18**

## **1 Important instructions and warnings for safety and environment**

This section contains safety instructions that will help protect from risk of personal injury or property damage. Failure to follow these instructions shall void any warranty.

### **General safety**

- Risk of Toxicating! While the appliance is operating, air in the entire house is sucked. If adequate ventilation is not provided, waste and toxic gasses which are released as a result of burning will be drawn back into the house through chimney draught. Do not operate the appliance together with sources that may emit toxic gasses and create air draught (wood, gas, oil, and coal stoves, water heaters, kettles, etc.).
- Always have the authorized persons check the adequacy of ventilation and chimney draught in your building.
- The appliance is not intended for use by persons (including children) with reduced physical, sensory or mental capabilities, or lack of experience and knowledge, unless they have been given supervised or instruction concerning use of the appliance by a responsible person for their safety. Young children should be supervised to ensure that they do not play with the appliance. Cleaning and user maintenance procedures should not be performed by the children unless they are under supervision.
- Always have the installation and repair procedures performed by Authorised Service Agent. Manufacturer shall not be held responsible for damages arising from procedures carried out by unauthorised persons.
- Do not operate the appliance if it is defective or has any visible damage.
- Make sure that the appliance is switched off after every use.
- If the product is handed over to someone else for personal use or second-hand use purposes, the user manual, product labels and other relevant documents and parts should be also given.
- Call Authorised Service Agent for the installation of the appliance. Warranty period will start after this procedure.

### **Electrical safety**

- To get your product ready for use, firstly you must have installation place and electric wiring prepared. Later, you may call Authorised Service nearest to you.

- If it has a failure, the product should not be operated without being repaired by the Authorised Service Agent. There is the risk of electric shock!
- Never connect the hood before installation is completed.
- Never touch the plug with wet hands! Do not unplug by pulling from the cable; always hold by the plug to unplug.
- Product must be disconnected from the mains during installation, maintenance, cleaning and repair procedures.
- When the power cable is damaged, have it replaced by the nearest service agent.
- Never connect power cable near to the hobs. If melted down, cable may lead to fire.
- Any work on electrical equipment and systems may only be carried out by authorised and qualified persons.
- In case of any damage, switch off the product and disconnect it from the mains. To do this, turn off the fuse at home.
- Make sure that fuse current is compatible with the product.
- Never wash down the product with water! There is the risk of electric shock!

## Product safety

- The height between the lower surface of the hood and upper surface of the hob should not be less than 650 mm.
- Never touch the hood's lamp after they operated for a long time. Hot lamps may burn your hands.
- Never operate the product without oil filter. Never remove filters when the product is in use.
- Avoid big flames beneath the product. Otherwise, particles on oil filter may flame up and cause fire.
- Turn on the hobs after placing pans or pots on. Otherwise, rising temperature may deform certain parts of your product.
- Turn off the hobs before taking away pans or pots.
- Avoid inflammable materials under the hood.
- Do not expose the product to open flames beneath it. It can cause oils accumulated in the filter to catch fire. Do not operate the product without filter.
- Never leave the cooker unattended when frying foods, the oil may flame up and boiled oil may cause fire. Thus, be careful about cloths and curtains.
- If the hood is not periodically and properly cleaned, this may cause burning risk on your hood.

- For refreshing the kitchen's air from cooking smells and steams, please turn on your hood for 15 minutes more after cooking or frying has ended.
  - There shall be adequate ventilation of the room when the range hood is used at the same time as appliances burning gas or other fuels. (Not applicable to appliances that only discharge the air back into the room)
  - In the environment where the hood is being used, the exhaust of fuel oil or gas devices such as room heater must be absolutely insulated or device must be hermetical type.
  - If there is a fuel oil or gas device in the environment, the room must be ventilated sufficiently.
  - When a non-electrically operated device is concurrently used in the environment together with the hood, the negative pressure in the room must be maximum 0.4 mbar to avoid the hood's returning other device's exhaust into the room.
  - Never connect the hood to the chimneys used for heaters, waste gas or with rising flames. Observe authorities' regulations on the draining of output air.
  - When connecting to the chimney, use 120-mm diameter pipes.
- Pipe connection must be as short as possible with fewer bends.
  - Do not hang easily flammable and combustible materials on hood handles.
  - Our company shall never be responsible for the problems arising from the use against the warnings above.
  - There is a risk of fire if cleaning is not carried out in accordance with the instructions.
  - Do not flambé under the range hood.
  - Caution: Accessible parts may become hot when used with a cooking appliance.
  - You are recommended to clean your filter once a month in normal use.

#### **Intended use**

This product is designed for domestic use. Commercial use is not admissible.

The manufacturer shall not be liable for any damage caused by improper use or handling.

Service life of your product is 10 years. Manufacturer shall provide the required spare parts for the product to perform as defined during this period.

## Children's safety

- Keep children away from the product when it is operating and do not allow them to play with the product.
- Packaging materials are dangerous to children. Keep the packaging materials in a place where children cannot reach and sort and discard them in accordance with the waste disposal directives.
- Electrical products are dangerous to children. Keep children away from the product when it is operating and do not allow them to play with the product.

## Compliance with AEEE regulation and disposal of waste products

- This product does not contain harmful and forbidden materials described in the "Directive on the Restriction of the Use of Certain Hazardous Substances in Waste Electrical and Electronic Equipment" (AEEE) issued by the T.R. Ministry of Environment and Urbanization. Complies with the AEEE Directive.



- This product has been manufactured with high quality parts and materials which can be reused and are suitable for recycling. Therefore, do not dispose the product with normal domestic waste at the end of its service life. Take it to a collection point for the recycling of electrical and electronic equipment. Please consult your local authorities to learn the nearest collection point. Help protect the environment and natural resources by recycling used products. Before disposing of the product, cut off the power cable plug and make the door lock (if any) unusable to avoid dangerous conditions to children.

## Package information

- Packaging materials of the product are manufactured from recyclable materials in accordance with our National Environment Regulations. Do not dispose of the packaging materials together with the domestic or other wastes. Take them to the packaging material collection points designated by the local authorities.

## 2 General information

### Overview

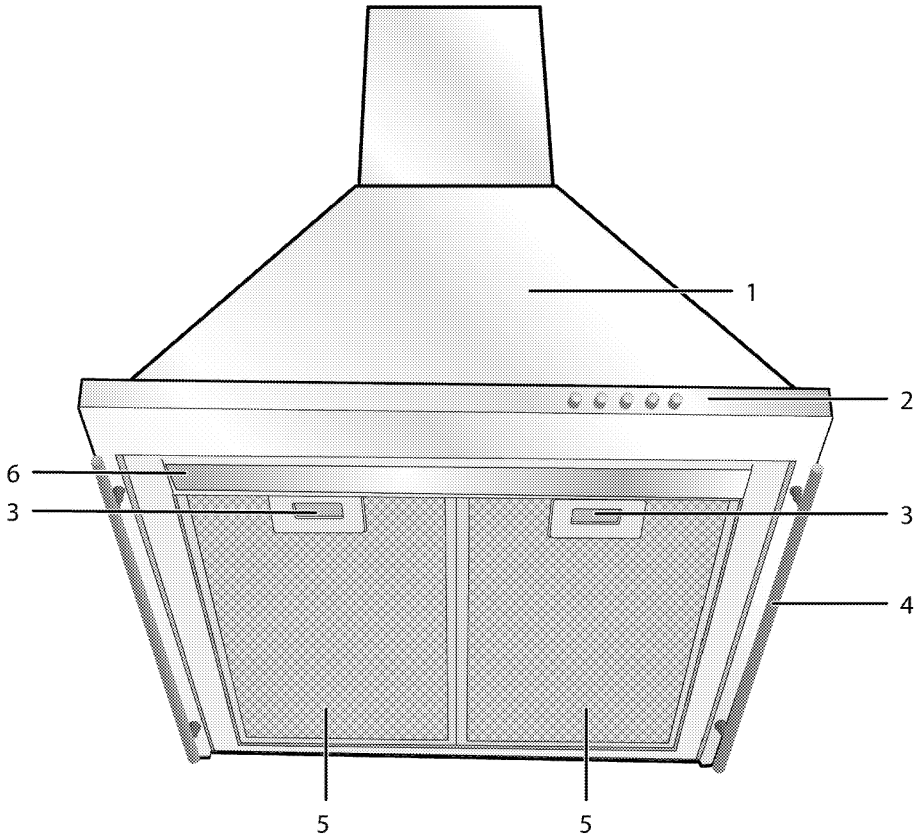

- 1 Hood body
- 2 Control panel
- 3 Aluminum filter lock

- 4 Handle
- 5 Aluminum filter
- 6 Lamp

## Scope of delivery



Accessories supplied can vary depending on the appliance model. Not every accessory described in the user manual may exist on your appliance.

1. User manual
2. Wall connector

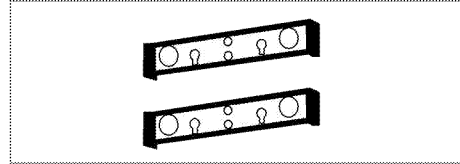

3. Air directing component optional

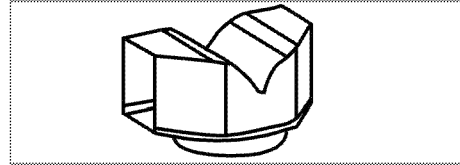

4. Chimney connection adapter

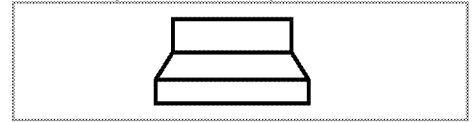

5. Valves to prevent reverse air flow



6. Distance ring



## Technical specifications

External dimensions (height/width/depth)	min.735 mm max. 1130 mm/600 mm/502 mm
Voltage/frequency	220-240 V , 50 Hz
Control	3 level
Suction power	480 m <sup>3</sup> /h
Total power consumption	max. 200 W
Fuse	min. 10 A
Air outlet pipe diameter	120 mm



Technical specifications may be changed without prior notice to improve the quality of the product.



Figures in this manual are schematic and may not exactly match the product.



Values stated on the markings of the product or in other printed documents supplied with the product are obtained under laboratory conditions as per relevant standards. Depending on operational and environmental conditions of the product, these values may vary.

### 3 Installation

Refer to the nearest Authorised Service Agent for installation of the product. Make sure that the electric installations are in place before calling the Authorised Service Agent to have the product ready for operation. If not, call a qualified electrician and fitter to have the required arrangements made.

**i** Preparation of location and electrical installation for the product is under customer's responsibility.

**DANGER:**  
The product must be installed in accordance with all local electrical regulations.

**DANGER:**  
Prior to installation, visually check if the product has any defects on it. If so, do not have it installed. Damaged products cause risks for your safety.

**DANGER:**  
Warning: Failure to install the screws or fixing device in accordance with the instructions may result in electrical hazards.

#### Installation

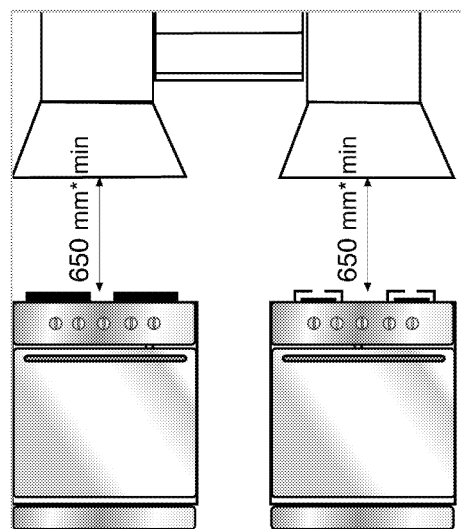

\* min.

The minimum distance between the supporting surface for the cooking vessels on the hob and the lowest part of the range hood is 65cm.

The exhaust air must not be discharged into a flue which is used for exhausting fumes from other appliances burning gas or other fuels. (Not applicable for appliances which only discharge air back into the room) Regulations concerning the discharge of air have to be fulfilled.

#### Electrical connection

Manufactured with 2-track power cable, this device must be connected to the mains by an electrical switch with at least 3mm clearance between bipolar contact leads. Have a qualified electrician to install electric wiring.

- Install your product to ensure easy access to electricity connection (plug, wall outlet) after installation.

#### Installing the hood

**i** Dimensions are given in mm.

Information required for the preparation of the installation place for your hood is given below. Hood should be placed as aligned by the central axis of the cooking appliance. Cooking appliance and the hood's oil filters should be at least 650mm away from each other. Perform the following steps for the installation of the hood.

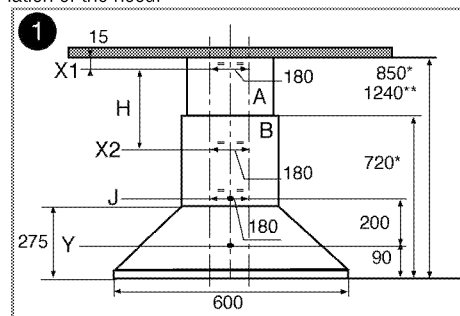

\* min.

\*\* max.

1. Centering the cooking appliance, draw an axis line on the wall up to 950mm height. Later, draw two parallel lines at 90mm distance on both sides of the axis line reaching to the ceiling. Then, determine hole locations by drawing the lines Y-J-X2 and X1 that cut vertically the axis line, for which measurements are given in Figure 1.
2. Drill eight 8-mm holes on the points X, Y, X2, X1 and place plastic plugs supplied with the packag-

ing. Check whether the holes of the flue connection parts correspond to these holes or not.

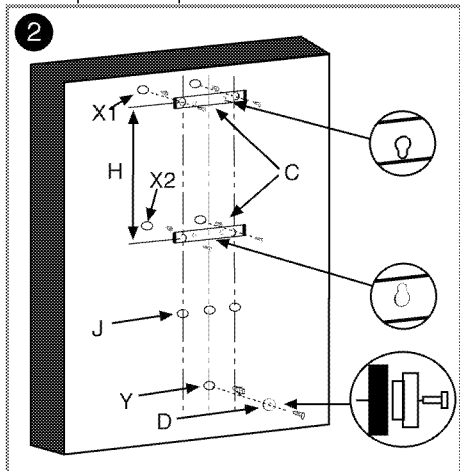

3. As shown in Figure 2, fix connectors (C) to the holes X1 and X2 via two fixing screws supplied with the accessories. Screw distance ring (D) on the Y hole as small-diameter side facing the wall.

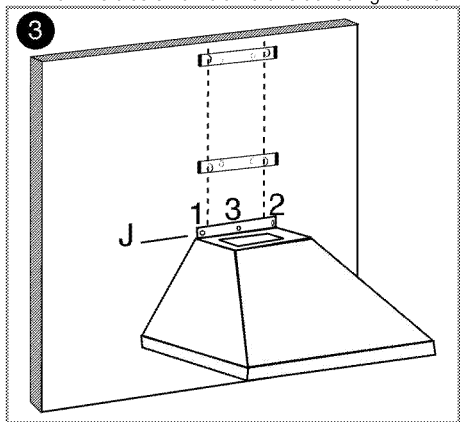

4. Install the hood from the key hole on back plate onto the distance ring and pull downward to make sure that it is secured. Then, screw the body onto the wall from the holes J1 and J2 on the upper back of the body. To avoid the hood falling down accidentally for any reason, screw it also from the hole J3 shown in Figure 3.

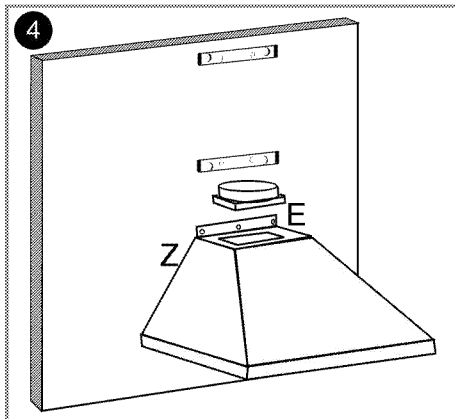

5. As shown in Figure 4, place chimney outlet flange (E) to the rectangular outlet on the upper part of the hood; and screw the flange onto the body using 2.9-mm traced screws supplied with accessories.

**6. For chimney connection usage:**

In chimney-connected position, absorbed air will go through oil filters to the outlet and then will reach to the chimney though connection pipes and finally thrown out from the chimney.

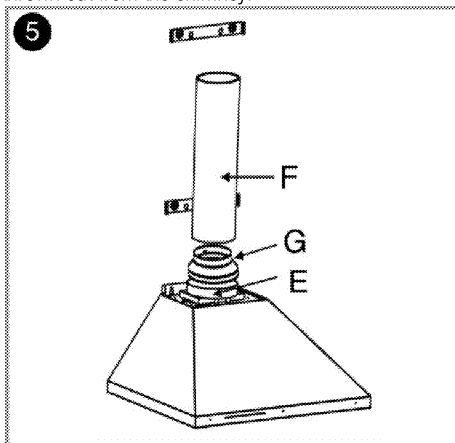

When using this connection position, 150mm to 120 mm E connector should be installed on chimney outlet flange as shown in Figure 5.

Chimney connection pipes must be made of fireproof plastic material. When using flexible connection type, it should be considered that sharp corners and sudden contractions will have a negative impact on air suction. Flue connection should in no way be made to any flue to which another device was already connected for another purpose.



Connection pipe should not be bigger than 120 mm; on the contrary, this application prevents proper chimney connection.

### 7. Internal circulation (Use with carbon filter)

Vacuumed air in the medium in the internal circulation position is delivered back to the medium from over the grills on the flue after it passes through the oil filters, the carbon filters where it is cleaned from odours, and the air deflector.

6

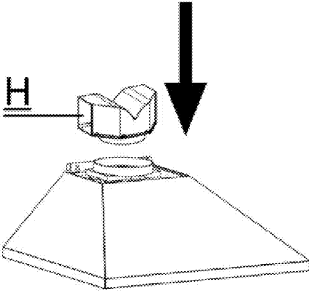

As shown in Figure 6, air directing component is installed on H point.

7

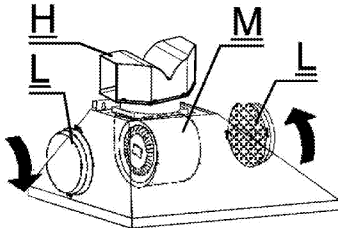

Place ear slots of carbon filters (L) to the ears on motor carrier (M) as shown in Figure 7 and turn anti-clockwise to fix in place. Apply the same procedure for the motor carrier on the other side.



In case of failure to perform cleaning and maintenance of oil filters regularly and when the carbon filter reaches its service life (about 4 months), there is the possibility of causing fire by them.

### 8. Flue installation

To install upper chimney A, secure the upper corners of the chimney on the connection (C) as shown below and screw it onto the connector with 2.9-mm screws.

8

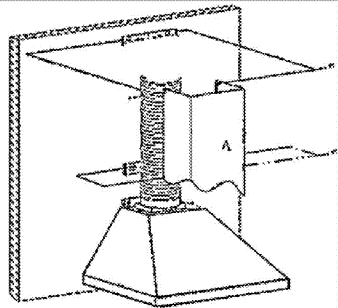

Distance between the hole X1 and X2 is determined during the installation process depending on the usage length of the upper chimney.

9

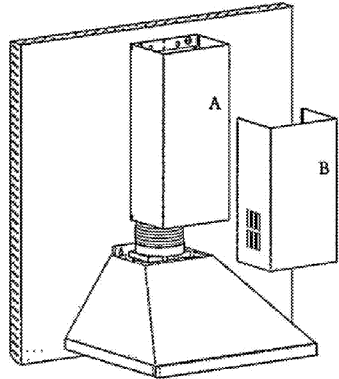

To install lower chimney B, stretch the chimney by pulling slightly from both sides and secure it onto upper chimney's slots as shown in the above figure.

### You can use your hood in two ways:

#### 1- Chimney-connected use

Vapors are discharged with the flue pipe secured on the connection ring on the hood. Diameter of the flue pipe should be equal to the diameter of connection ring. To allow the air easily going out of the room in horizontal arrangements, the pipe should be slightly tilted upwards (approximately 10°).



Carbon filter should be removed if it is installed in the hood.

#### 2- Use with no chimney connection

Air is filtered by the carbon filter and returned to the room. Carbon filter is used when there is no flue available in the house or when it is not possible to install the flue pipe.

- Remove aluminum filters as shown below.

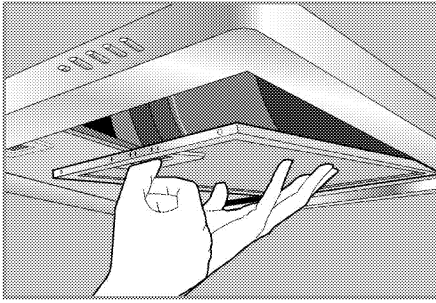

- To install the carbon filter, center the carbon filter on the plastic part on both sides of the fan body, and secure it on the tabs.
- Tighten by turning it to right and left as shown in the figure.

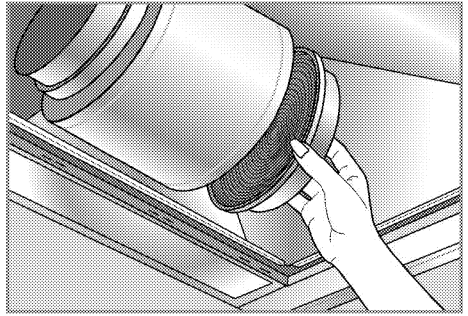

- Reinstall the aluminum filters.

### **Future transportation**

- Keep the product's original carton and transport the product in it. Follow the instructions on the carton. If you do not have the original carton, pack the product in bubble wrap or thick cardboard and tape it securely.



Do not place any objects onto the product and move it in upright position.



Check the general appearance of your product for any damages that might have occurred during transportation.

## 4 Operating the hood

Hood is equipped with a motor with various speed settings.

For a better performance, we advise you to use low speeds in normal conditions, and high speeds when smell and vapors are intensified.

### Operating the hood

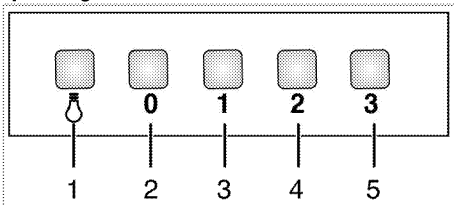

- 1 Lamp button
- 2 Off button
- 3 Speed1
- 4 Speed2
- 5 Speed3

### Turning off the hood

#### Operating the lamp

1. Press on the lamp button to operate the lamp.

#### Turning off the lamp

1. Press on the lamp button again to turn off the lamp.



Off button do not turn off the lamp, it only stops operation of the hood.

## 5 Maintenance and care

### General information

Service life of the product will extend and frequent problems will decrease if the product is cleaned at regular intervals.



#### **DANGER:**

Disconnect the product from mains supply before starting maintenance and cleaning works.

There is the risk of electric shock!

- Clean the product thoroughly after each use. In this way it will be possible to remove cooking residues more easily, thus avoiding these from burning the next time the appliance is used.
- No special cleaning agents are required for cleaning the product. Use warm water with washing liquid, a soft cloth or sponge to clean the product and wipe it with a dry cloth.
- Do not use cleaning agents that contain acid or chloride to clean the stainless or inox surfaces and the handle. Use a soft cloth with a liquid detergent (not abrasive) to wipe those parts clean, paying attention to sweep in one direction.



The surface might get damaged by some detergents or cleaning materials.

Do not use aggressive detergents, cleaning powders/creams or any sharp objects during cleaning.



Do not use steam cleaners for cleaning.

### Aluminum filter

This filter captures oil particles in the air. You are recommended to clean your filter once a month in normal use. Please firstly remove aluminum filters for this process. Wash the filters in liquid-detergent water and install them after drying. Aluminum filters might change colour in time due to washing. This is normal and you don't need to replace the filter.

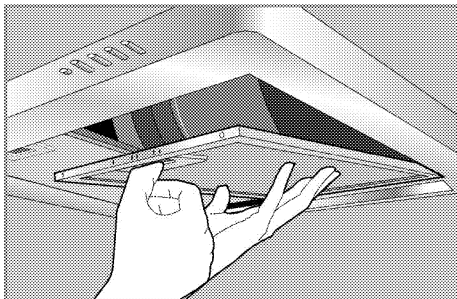

You can also wash aluminum filters in dishwasher.

### Removing aluminum filters

1. Push aluminum filter lock forward.
2. Slightly lower the filter and pull forth. Otherwise, you may bend the filter.
3. After washing, reverse the steps above to re-install the aluminum filter.

### Carbon filter (Use without chimney)



Carbon filter should never be washed.

It should be replaced once every 4 months in normal use. You may obtain carbon filters from the Authorised Service.

### Removing carbon filters

1. Remove aluminum filters
2. To remove carbon filter, turn it to release from the tab.

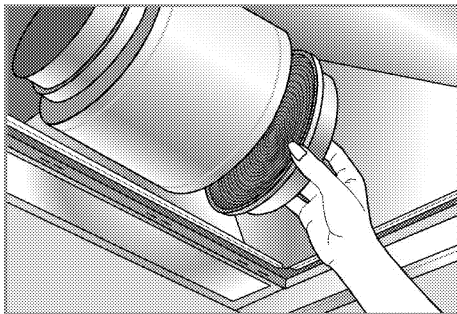

3. Install the new carbon filter.
4. Re-install aluminum filters.



You may cause fire if you do not observe the rules regarding the cleaning and replacing hood filters.

## Removing hood handle

1. Remove aluminum filters by pushing the locks.
2. Loosen the nuts aligned with handles from inside the hood.

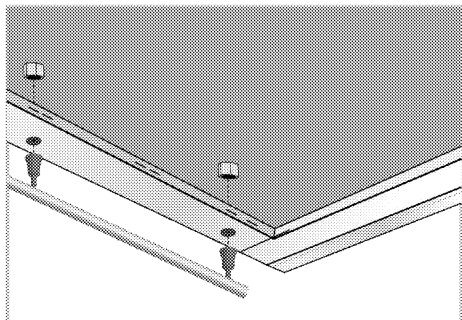

3. Fix the handles by tightening with the nuts, again from inside the hood.
4. Re-install aluminum filters.



Handles will be mounted by the service in countries where service support is given.

## Replacing the lamp



### DANGER:

Before replacing the lamp, make sure that the product is disconnected from mains in order to avoid the risk of an electrical shock. If hot, let the lamp cool down.  
Hot surfaces may cause burns!



For the specifications of the lamp, see *Technical specifications, page 9*. Oven lamps can be obtained from Authorised Service Agents.



Position of lamp might vary from the figure.



The lamp used in this appliance is not suitable for household room illumination. The intended purpose of this lamp is to assist the user to see foodstuffs.

1. Push lamp tabs forward to remove lamp plastic part as shown.

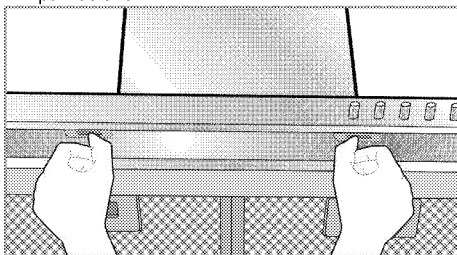

2. Replace the lamps.
3. Place the lamp plastic part in the same slot and secure plastic tabs. The plastic part will be seated with a "click" sound.

## 6 Troubleshooting

### **Product does not operate.**

- The mains fuse is defective or has tripped. >>> *Check fuses in the fuse box. If necessary, replace or reset them.*
- Product is not plugged into the socket. >>> *Check the plug connection.*
- Speed button might not be set. >>> *Press the required speed button.*
- Power is cut. >>> *Check if there is power. Check the fuses in the fuse box. If necessary, replace or reset the fuses.*

### **Hood light does not work.**

- Hood lamp is defective. >>> *Replace the hood lamp.*
- Power is cut. >>> *Check if there is power. Check the fuses in the fuse box. If necessary, replace or reset the fuses.*



Consult the Authorised Service Agent or the dealer where you have purchased the product if you cannot remedy the trouble although you have implemented the instructions in this section. Never attempt to repair a defective product yourself.

## 7 Consumer Services

### Dear Valued Customer,

Arçelik Call Center provides services 24 hours, 7 days a week.

You can dial our call centre number without adding an area code from your mobile or fixed phones and ask for any service related with your product.

The calls you made to our call centre may be charged by your service provider based on your defined tariff.

You can also access our call centre by completing the form in "Consumer Services" section on the [www.com.tr](http://www.com.tr) website or by sending a fax to 0216 423 23 53.

For correspondence, our address is: Arçelik Çağrı Merkezi, Arçelik A.Ş. Ankara Asfaltı Yarı, 34950 Tuzla/İSTANBUL

**Arçelik Call Centre**  
**444 0 888**

(Call the number without dialing the area code from your fixed or mobile phones)

**Alternative Number**  
**0216 585 8 888**

### Please follow the recommendations below.

- 1 When you purchase the product, have its Warranty Certificate approved by your Authorised Dealer.
- 2 Follow the instructions in user manual when using your product.
- 3 Please contact our Call Centre from the phone numbers above to submit your service request.
- 4 Please ask the service technician to present his/her "technician ID".
- 5 Do not forget to ask a "Service Receipt" from the technician when your job is completed. The "Service Receipt" you receive will be useful in case of any future problems related to your product.
- 6 Service life of the product is 10 years. (The manufacturer will provide spare parts during this period to ensure the product's operation)

### Customer Satisfaction Policy

As Arçelik A.Ş., we adopt a customer oriented approach accepting the fact of providing superior customer experience without making any client profile discrimination by enabling the transmission of customer requests and suggestions for our brand that we provide service through all channels (call centre, e-mail, [www.com.tr](http://www.com.tr), facsimile, letter, social media, resellers), collecting these in a single traceable, reportable, transparent and reliable information repository, handling and evaluating these in an objective, fair and confidential way as per the legal regulations, and continuously checking and improving the processes. In line with our approach, all processes are integrated with the management system, a self-checking structure has been developed and also the management targets are fed through this system.

### Evaluating the service request

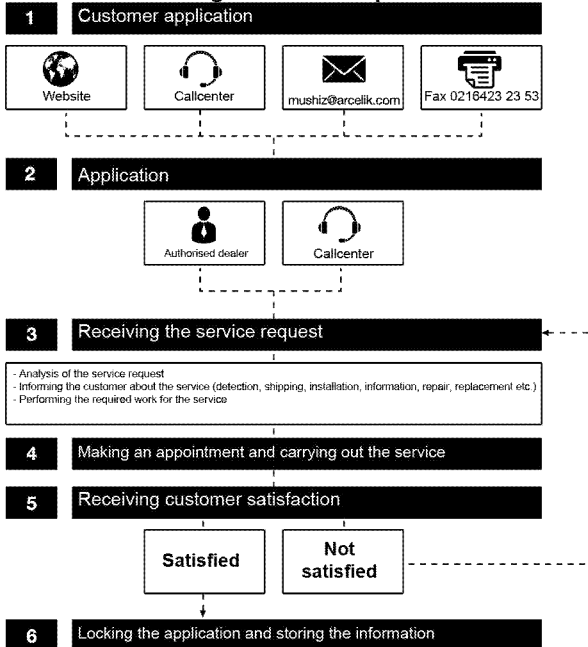

## *Usage Errors and Points to Take Into Consideration Regarding the Warranty*

*The issues specified below are remedied for a certain fee. The terms of warranty are not applied to these situations;*

- 1) Damages and failures resulting from usage errors,*
- 2) Damages and failures emerged during loading, unloading, transportation etc. after the product has been delivered to the customer;*
- 3) Damages and failures resulting from the electricity, water, natural gas, telephone mains and/or network etc. or infrastructure where the product is being used,*
- 4) Damages and failures resulting from nature events, fire, floods etc.,*
- 5) Damages and failures resulting from using the product contrary to the points specified in the introduction and user manuals of the product,*
- 6) Damages and failures resulting from using the product with commercial or professional purposes as specified in the Law No. 6502 on Consumer Protection,*

*The granted warranty will become void in the case that the product is maintained, repaired or interfered with any other purpose by unauthorised persons.*

*The warranty period of the product replaced within this period is limited to the remaining time of the previous product.*

*Manufactured by Arçelik A.Ş.  
Origin: Turkey*

Call Centre  
**444 0 888**

The Other Number  
**0216 585 8 888**

Arçelik A.Ş. Karaağaç Caddesi No:2-6,  
34445, S t l ce / İSTANBUL  
Tel.:(0-216) 585 85 85 Fax: (0-216) 423 23 53

# Hood

## CERTIFICATE OF WARRANTY

### CERTIFICATE OF WARRANTY

- 1) The warranty period shall commence upon the delivery of the product and is specified as 2 years.
- 2) Starting from the delivery date, this warranty shall cover the whole product including all the parts incorporated for material, workmanship and manufacturing errors during the period specified above on the condition that the product has been used in accordance with the introductory and user manuals and has not been interfered for maintenance, repair or another purpose by persons other than those authorised by Arçelik A.Ş.
- 3) If the product is defective, in compliance with the clauses laid down in the Article 11 of the Law no. 6502 on Consumer Protection; the consumer shall become entitled to use one of the rights listed below:
- a- To cancel the contract,  
b- To claim a deduction on the sale price,  
c- To claim a free of charge repair,  
d- To claim product replacement with a free of defects equivalent.
- 4) If the consumer prefers his/her right to get a free of charge repair; the seller shall be liable for repairing the product or have it repaired without charging any fees under the name of labour cost, replaced part cost or any other reason. Also, the consumer shall be able to use his/her right to get a free of charge repair against the manufacturer or the importer. The seller, the manufacturer and the importer shall be severally liable for the customer to use this right.
- 5) In the case that the consumer uses his/her right to get a free of charge repair; if:  
- The product breaks down again within the warranty period,  
- If the maximum duration required for repair is exceeded,  
If the authorised service centre, the seller, the manufacturer or the importer designates the product as irreparable;  
the consumer shall be entitled to claim refund, deduction on the price in the ratio of the defect or a replacement with a free of defect equivalent, if present, from the seller.  
The seller shall not have the right to reject the consumer's claim. The seller, the manufacturer and the importer shall be severally liable in the event that this claim has been rejected.
- 6) The maximum repair duration for the product cannot exceed 20 workdays during its service life specified in the relevant legislation. This period shall commence; on the date of submitting the failure of product to the authorised service centre or to the seller within the warranty period, or on the date of delivery of the product to the authorised service station out of the warranty period. If the product under warranty cannot be repaired within 10 workdays, the manufacturer or the importer shall; be obliged to assign another product with similar specifications to the consumer's use until the defective product is repaired. If the consumer does not demand another product with similar specifications, the manufacturer or the importers shall be released from this obligation. If the product breaks down within the warranty period, the down time shall be added to the warranty period.
- 7) Damages and failures resulting from using the product contrastively with the rules specified in the user manual are not covered by the warranty.
- 8) The consumer shall be able to go to the Consumer Arbitration Court or the Consumer Court found in the area where the place of residence is included or where the consumer processes are carried out in the case of disputes regarding the rights that come with the warranty.
- 9) If this certificate is not provided by he seller, the consumer shall have the right to refer to the Ministry of Customs and Trade Consumer Protection and the General Directorate of Market Surveillance.

#### Manufacturer's or Importer's:

**Title:** Arçelik A.Ş.  
**Address:** Arçelik A.Ş. Karaağaç Caddesi No:2-6, 34445,  
Sıtlıce / İSTANBUL  
**Phone:** (0-216) 585 8 888  
**Fax:** (0-216) 423 23 53  
**web address:** www.altus.com.tr

#### The Product's

**Brand:**  
**Type:** Hood  
**Model:**  
**Banderole and Serial No:**  
**Warranty Period:** 2 YEAR  
**Maximum Repair Duration:** 20 Workdays

GENERAL MANAGER

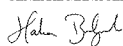

**Arçelik A.Ş.**

DEPUTY GENERAL MANAGER

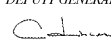

#### The Seller's:

**Title:**  
**Address:**  
**Phone:**  
**Fax :**  
**e-mail:**

**Date and Number of Invoice:**  
**Date and Place of Delivery:**  
**Authorised Signature:**  
**Company Seal:**

The Authorised Seller who sold you the product shall sign and stamp this field.